

Installation and Operating Instructions

Domestic Hot Water Heat Pump Air/Water Indoor **WWK 300**



STIEBEL ELTRON (Aust) Pty Ltd
Freecall 1800 153 351
www.stiebel.com.au

Melbourne 9645 1833 / Sydney 8399 1088
Brisbane 3399 3999 / Perth 9248 7570
Adelaide & Darwin 1800 153 351

CONTENTS

Specifications of the unit.....	3
1. Operating instructions	4
1.1 Operation and control	
1.2 Equipment description and operation	
1.3 Incorrect operation	
1.4 Description of functions	
1.5 Operation outside the limits	
1.6 Maintenance and cleaning	
1.7 Operation and control	
1.8 Troubleshooting	
2. Safety equipment and maintenance for contractors...	8
2.1 On the equipment	
2.2 On the system	
3. Installation for contractors.....	10
3.1 Transport	
3.2 Positioning	
3.3 Water connection	
3.4 Electrical connection	
4. Commissioning.....	13
5. Shutting down the equipment	14
6. Warranty.....	15

SPECIFICATION

Type	WWK 300	
Part no.	74361	
Operational limits of the heat pump	°C	+6 to +35
Electric heating element	°C	+65 (fixed)
Air volume / throughput	m ³ /h	550
Cylinder capacity	L	303
Refrigerant / filling volume	--/g	R 134a / 850
Dimensions H / W / D	mm	1792 / 660 / 690
Weight dry / filled	kg	150 / 455
Voltage / frequency	V/Hz	L/N/PE ~ 240 / 50
Water connections (male thread)	mm	25 (1")
Circulation connection (male thread)	mm	12 (1/2")
Condensate connection	mm	12
Maximum cold water inlet pressure	kPa	500*
Maximum PTR Valve operating pressure	kPa	600
Maximum power consumption of heat pump ¹	kW	0.53
Heating capacity ²	kW	approx 1.6
Coefficient of Performance (COP) ²		4.1
Power consumption of electric heating element	kW	1.5
Condenser type		Safety heat exchanger

* WA & QLD require the installation of cold water expansion valves (500kPa) therefore a maximum cold water inlet pressure must not exceed 350kPa.

¹ Test point at 35° C air temperature, 70% relative humidity and 60° C water temperature.

² Average value at 15° C air temperature, 70% relative humidity and heating water by 45° C

1. OPERATING INSTRUCTIONS

1.1 Operation and control

The WWK300 domestic hot water (DHW) heat pump from STIEBEL ELTRON is an automatic DHW heater offering a hot water storage capacity of 300 L.

Your local contractor must install, connect and commission your WWK300. Nevertheless, you should familiarise yourself with the most important aspects of this equipment.

1.2 Equipment description and operation

The WWK 300 contains two heat sources; both heat the water to the required temperature:

- Heat pump
- Electrical supplementary heater within the cylinder

The WWK 300 is designed to intake air, extract energy from it and release this air at lower temperatures at its exhaust. With the energy extracted it heats the water in the storage cylinder producing domestic hot water (DHW). This process leads to cooling of the installation room by 1°-3° C approx. It can also be operated with a connection to an air duct, in which case air channels must not be smaller than 160 mm diameter and their length should not exceed 5 m (contact us for information). The WWK 300 also extracts moisture from the air, which turns into condensate and must be drained off. A hose connection is provided for that purpose.

1.3 Incorrect operation

Never:

- use greasy exhaust air
- heat liquids other than potable water (not suitable for heating swimming pools or spas)
- install the unit outside, in rooms at risk from frost, in rooms at risk from dust, gases or vapours liable to explode
- operate the unit with an empty cylinder

1. OPERATING INSTRUCTIONS

cont..

1.4 Description of functions

Heat pump operation

This is the standard operating mode for DHW production, to which the limits of scope of the heat pump apply (see specification table, page 3). Below are the heat up times the WWK300 requires to heat water in the tank by 45°C for three different ambient air temperatures.

Space	Humidity	Cold Water	Heat-up time	COP
6°C	70%	15°C	11.5 h	3.3
15°C	70%	15°C	9.0 h	4.1
35°C	47%	15°C	6.4 h	5.1



If the heat pump was manually switched OFF and ON again after a power failure, the compressor will only re-start (after approx. 15 minutes) when the pressure inside the refrigerant circuit has normalised again.

Electrical supplementary heater

You can accelerate the heating-up process with the electrical supplementary heater if the DHW demand increases or if the WWK 300 has previously been switched OFF and you require hot water as quickly as possible. For saving energy purposes, the electrical supplementary heater only heats the top third of the cylinder capacity (approx. 100 L) . This takes about 2 hours.

1.5 Operation outside the limits of use (between 4° C to 6°C)

Subject to relative humidity and the DHW temperature inside the cylinder, the evaporator begins to ice up below a room temperature of 6°C. When the evaporator is covered in hoarfrost, the frost stat N2 (see wiring diagram) shuts down the compressor while the fan continues to operate, thereby defrosting the evaporator. The compressor starts again automatically after the defrosting process has been completed and the heat pump operation continues.

The minimum temperature allowed for heat pump operation is +4°C. The evaporator is defrosted upon demand at operating temperatures between +4°C and +6°C. This increases the heat-up time.

Room temperature higher than 35° C

The heat pump will be switched OFF by safety equipment at room temperatures above approx. 35° C. It will re-start automatically after a brief cooling down period, but will be switched OFF again if the room temperature is still higher than 35°C.



Take appropriate steps to prevent the ambient temperature rising above 35°C

1. OPERATING INSTRUCTIONS

cont..

1.6 Maintenance and cleaning

The WWK 300 is largely maintenance free. Any maintenance, however, must only be carried out by qualified contractors.

The first inspection of the protective anodes is due after two years. Have the anodes checked regularly after that. Your contractor, who will be familiar with your local water quality, will advise you of the optimum timing for all maintenance. The Pressure Temperature Relief (PTR) valve is recommended to be replaced at intervals not exceeding 5 years*. The same rating valve **MUST** replace the existing one.

1.7 Operation and control

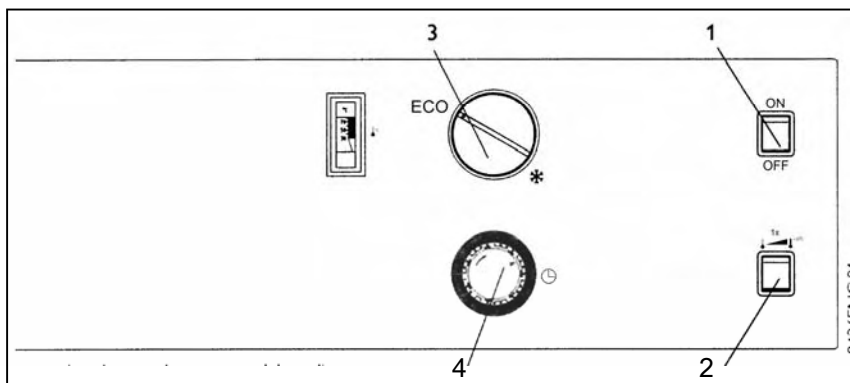

Fig. 1

Description of functions

- Switch (1) switches the heat pump ON or OFF.
- Using push button (2) you can activate a single quick heat-up of the cylinder via the electrical supplementary heater as mentioned before. After the top third of the cylinder capacity has reached a DHW temperature of 65° C, the electrical supplementary heater is switched OFF and will not be automatically switched ON again. Press this button only once and only to cover for a peak demand.
- An indicator lamp is integrated into the push button (2), which lights when the electrical supplementary heater is switched ON.
- Select the DHW temperature with the rotary selector (3) of the thermostat. Turn dial clockwise until it stops, this is the maximum temperature of 60° C.
- The time switch (4) is equipped with a week disc comprising 84 switching segments. The shortest switching period is 2 hours long. Segments pressed inwards towards the disc centre (a approx 2mm lift) are switched ON.
- The DHW display sensor captures the DHW temperature inside the upper third of the cylinder (a approx. 100 litres)



The temperature selector must be set to **MAX 60°C** to comply with AS/NZS 3500.

*This valve is not manufactured by STIEBEL ELTRON but by RMC and this is their recommendation

1. OPERATING INSTRUCTIONS

cont..

1.8 Troubleshooting by the user

Should you fail to obtain hot water at any time, you can take the following steps to remedy that situation.

No electrical power

Check the fuse/circuit breaker in your fuse box. If it has blown/tripped, replace/reset the fuse/MCB. Notify your local contractor if the MCB trips/fuse blows again when you switch it on again/replace it.

Still no hot water, even though power is available

Check for obstructed air inlet/outlet.

Other faults

Pressure temperature relief (PTR) valve on the hot water line drips

This may occur during the heat-up phase and is completely normal.

Condensate drain drips

This always happens when the surface temperature of the evaporator is lower than the ambient dew point temperature.

For all other faults, consult your contractor.

Note that DHW production can be maintained in most fault conditions by switching the electrical supplementary heater ON.

2. SAFETY EQUIPMENT AND MAINTENANCE for contractors

2.1 Equipment safety

In case of a fault, the safety equipment of the WWK 300 interrupts the relevant power circuit.



Turn off the power to the WWK 300 at the main switch board before commencing any work on the equipment.

High limit safety cut-out (STB)

This will shut the equipment down if the DHW temperature exceeds 95°C. Reset the high limit safety cut-out by pressing the reset button (item 2, Fig.3) after the cause of the fault has been removed. For this, open the equipment as shown in Fig.2.

Safety high pressure limiter (SDBK)

The safety high pressure limiter shuts down the compressor if the pressure inside the refrigerant circuit exceeds the permissible maximum value. The safety high pressure limiter may also respond if the WWK 300 is operated above its permissible limit (>35°C exhaust temperature). Reset the safety high pressure limiter by pressing the reset button (item 1, Fig.3) after the cause of the fault has been removed. For this, open the equipment as shown in Fig.2.

Protective motor switch

The protective motor switch will shut down the compressor if its temperature is too high because of excessive thermal load. Remove the relevant fault. After a short while, the protective motor switch will restart the compressor automatically.

Protective anode

Two magnesium anodes are integrated into the DHW cylinder to protect it against corrosion. These anodes are pushed through the flange from inside out and secured. For inspections, the flange will be removed to enable the simultaneous inspection of the electrode, the heater rod and the internal enamel coating. When replacing the anodes, ensure a perfect contact with a metallic conductive surface during assembly. The timing of the inspection is subject to the local water quality and is determined by your local contractor (see section 1.6).

Cleaning the evaporator

Maintaining the full output of the WWK 300 requires an occasional professional cleaning of the evaporator. Your contractor will determine the timing for this operation.

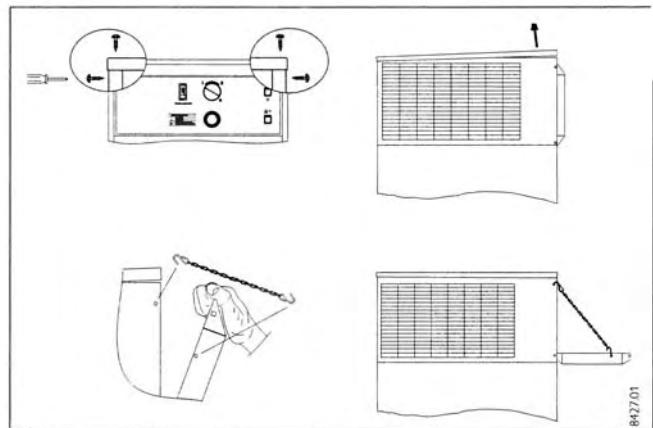

Fig. 2

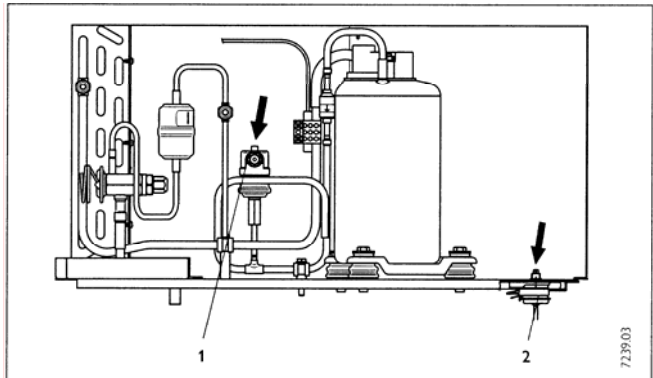

Fig. 3

2. SAFETY EQUIPMENT AND MAINTENANCE for contractors cont...

2.2 System safety

Pressure temperature relief valve, PTR (on-site provision)

This valve opens when the water pressure exceeds the preset value, thereby relieving the pressure. It is adjusted so that no water will be expelled when heating is switched OFF. Should it continue to drip excessively, either the valve seat has become contaminated, the water pressure is too high or the pressure limiting valve has become faulty.

Pressure reduction valve, PRV (on-site provision) *

Check the valve for correct operation and replace if necessary.

Regular valve maintenance

Safety requires that the valves are regularly checked. How quickly limescale builds up depends on the local water quality. As your local contractor is familiar with your local water quality, let him/her determine the timing of this check.

*A pressure limiting valve, PLV, cannot be used since it does not provide adequate pressure control as a PRV does

3. INSTALLATION for contractors

3.1 Transport

To protect the equipment against damage, it must be transported vertically inside its dedicated packaging. Where space is restricted, you may move the equipment tipped backwards at an angle.

3.2 Positioning

1. Remove the four screws from the non-returnable pallet.
2. Remove the washers.
3. Before removing the equipment from the pallet, remove the anti-vibration mounts from the pack supplied with the equipment and fully insert them at the base of the equipment.
4. Remove the equipment from its pallet and position it where required.
5. Level the equipment by manipulating the anti-vibration mounts.

Checking installation conditions

The room where the WWK 300 is to be installed must meet the following conditions:

- The unit must be installed Indoors or protected from the elements (Rain, etc)
- Stable floor (WWK 300 wet weight is approx. 455kg).
- Never operate the WWK 300 in rooms at risk from explosion due to dust, gases or vapours.
- Include in your considerations the utilisation of waste heat if possible, for example, from a boiler, tumble drier or refrigerator/freezer.
- The available floor area in the installation room must be at least 6m². Never install this equipment in rooms with a volume of less than 13m³.
- Never restrict the surroundings of the WWK 300 through walls or ceilings closer than shown in Fig.4.
- The room temperature must never fall below +6°C, as the ambient temperature will be reduced by approx. 1°-3° C from heat pump operation. The initial temperature level will be re-established approx. 1/2 hour after the heat pump has been switched OFF.

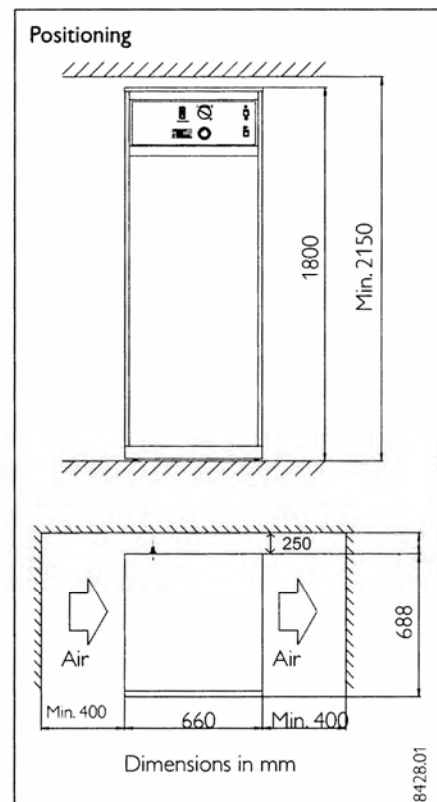

Fig. 4

3. INSTALLATION for contractors

3.3 Water connection

Observe the regulations imposed by your local water board. Install the cold water supply line in accordance with Fig.5.

To facilitate an easy connection to the water system, the equipment will be supplied with union nuts and flat gaskets for connection to the inlet and outlet.



To protect against the risk of corrosion, make the connection with the flat gaskets. The use of thread seal on the union connections is not acceptable

Insulate the DHW line in accordance with local regulations and AS3500 4.2. Please adhere strictly to the order of fittings on the cold water side (see Fig.5) . Prior to installation: Flush out the line. Install a 500 kPa pressure limiting valve when the water pressure is higher than 500kPa, this is recommended for all installs as the water pressure can fluctuate depending on the time of the day .

Condensate drain

The condensate drain from the WWK 300 is channeled to a drain via a hose (1/2 " diameter) .

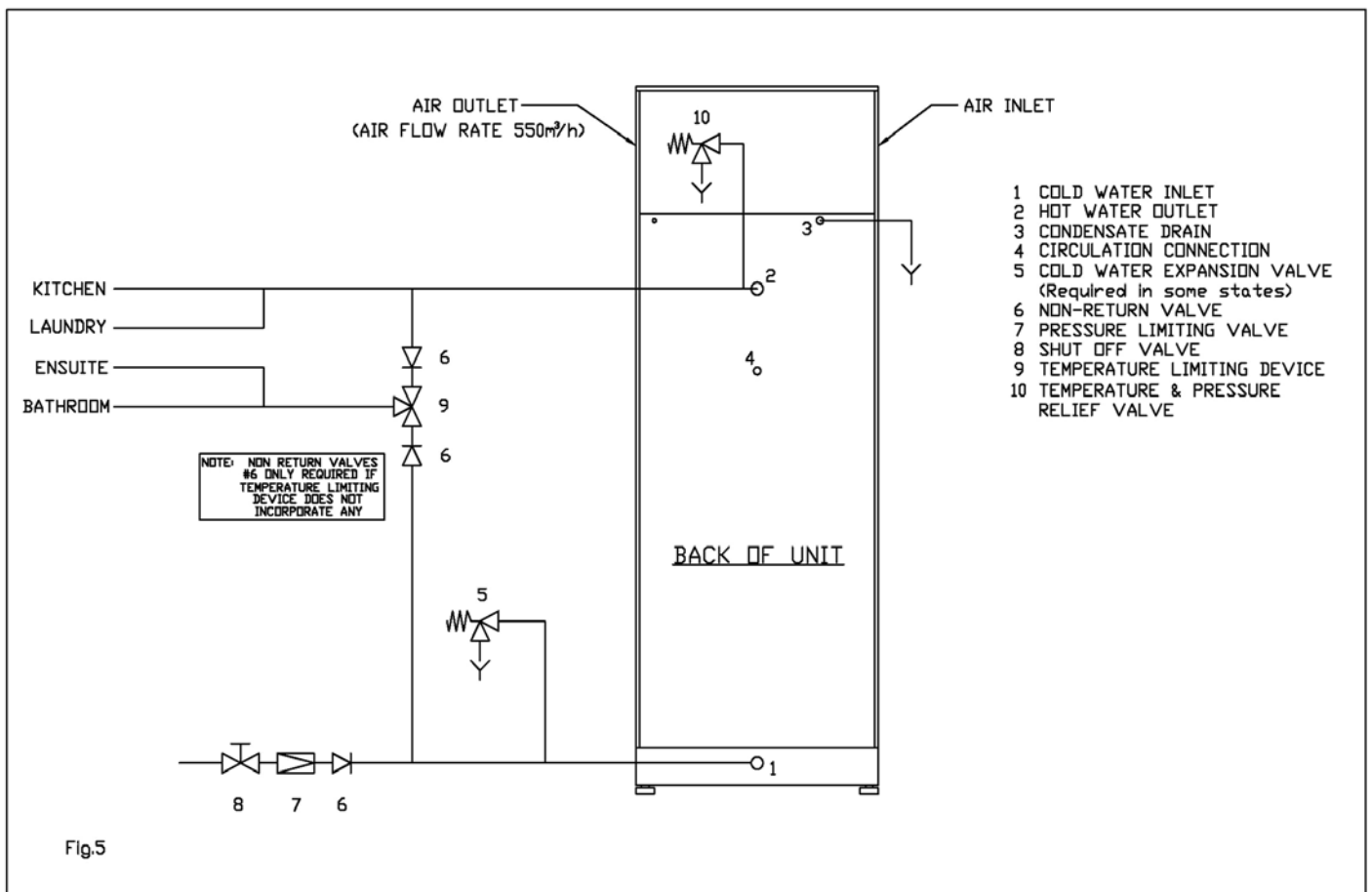

3. INSTALLATION for contractors cont...

Connecting a circulation line to the cylinder

A circulation line can be implemented with its return connected to the upper half of the cylinder (Fig. 5, item 4). The heat losses incurred in the circulation line and the electrical power consumption of the respective circulation pump, reduce the efficiency of the system. The cooled down water in the circulation line mixes with the cylinder content. Where possible, avoid installing a circulation line. Where it is not possible, control the circulation pump thermally or by a time switch.



Fill the cylinder with water before switching on power.

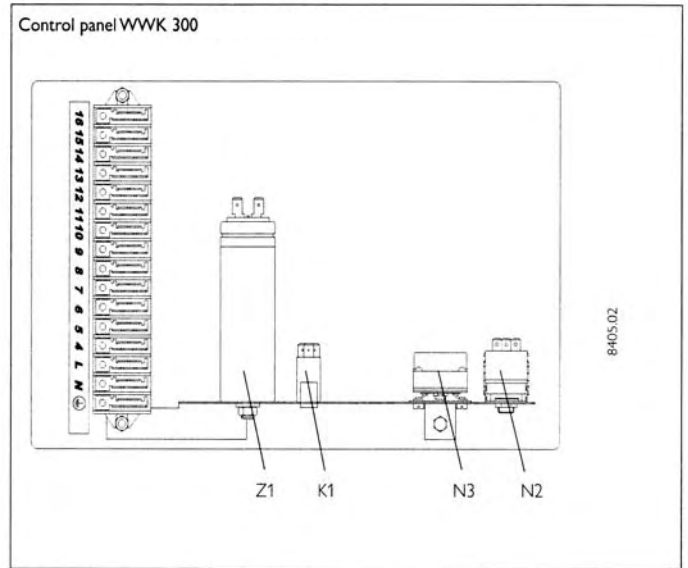

Fig. 7

3.4 Electrical connection

The WWK 300 is to be hard wired to a dedicated circuit with a line fuse rating of 16 A. Before connecting the power to the unit, verify that switch 1 is set to OFF (0) (see Fig.1).

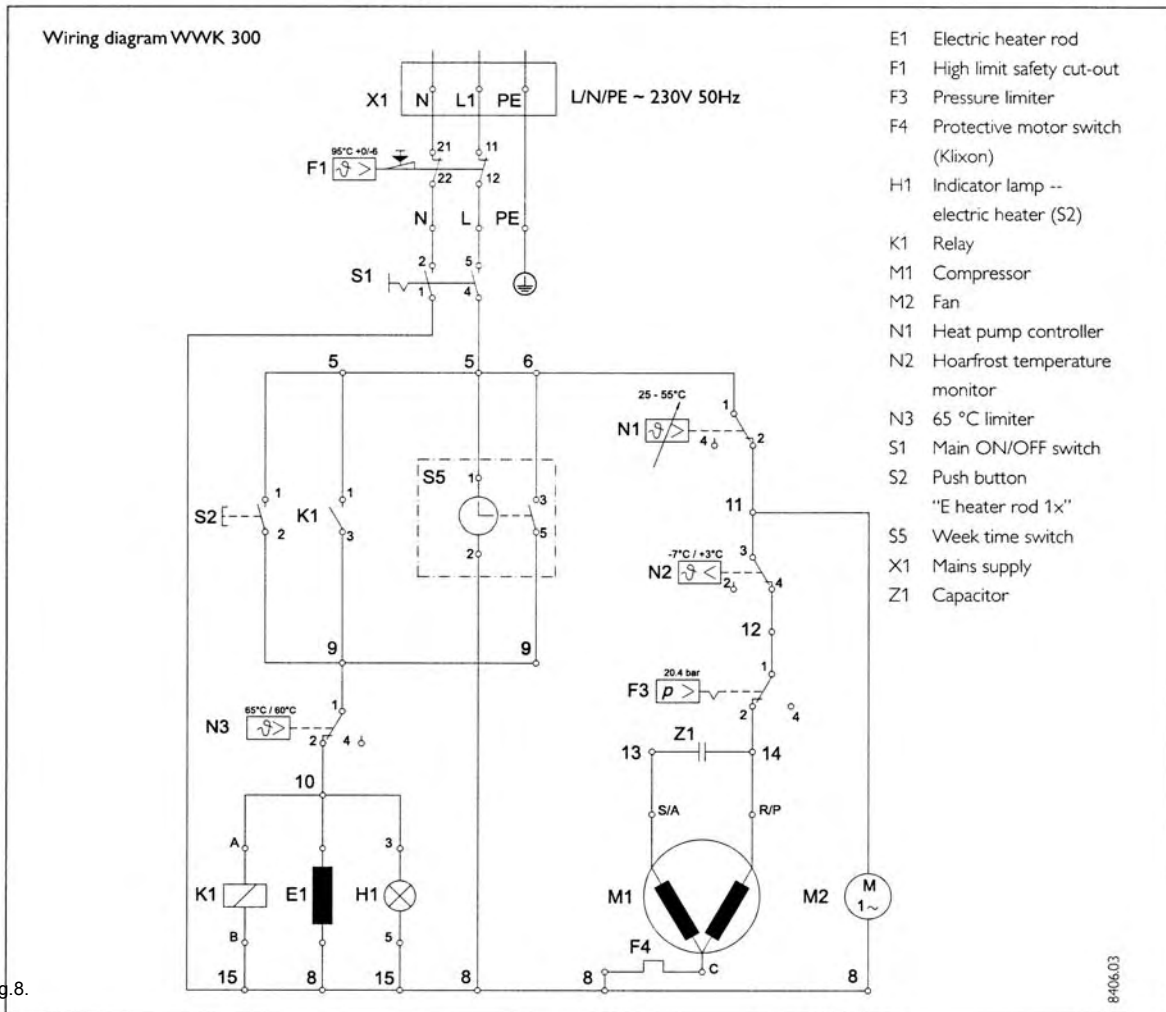

Fig.8.

8406.03

4. COMMISSIONING

Commissioning

Your local contractor must implement the commissioning: Fill the cylinder to prevent damage to the compressor and radiators. For filling, open all the taps in the house, open the water valve to the WWK 300 until water flows out the taps.

Close each tap when water is flowing freely from the taps with no air bubbles.

Starting the WWK 300:

- Set switch 1 to **ON**.
- Turn temperature selector (3) clockwise until it stops. This is the maximum temperature.
- Supplementary heater: Press push button 2; the indicator lamp inside the push button lights up. (This is only required to be activated if hot water is required straight away)

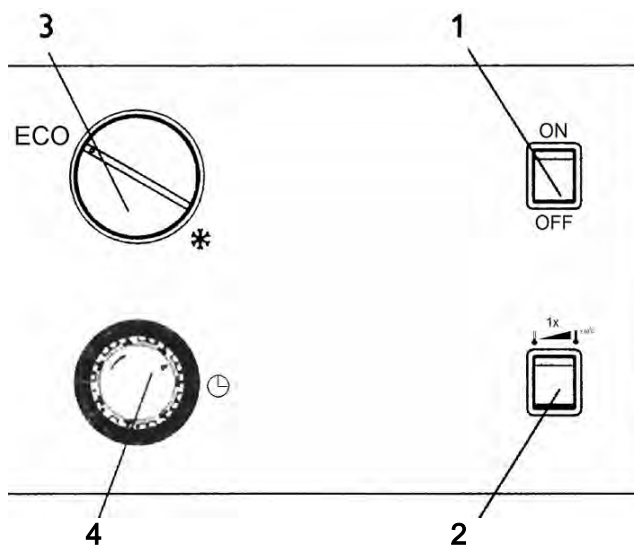

Inform the user that water may drip from the TPR valve whilst the water is being heated up.

Note - the timer (4) is only ever used if there will be a higher demand of hot water required. The timer will activate the supplementary heater.

5. SHUTTING THE EQUIPMENT DOWN

- Set switch 1 to **OFF** and remove the electrical supply at the isolating switch of the dedicated heat pump circuit.
- For reasons of good hygiene, drain the cylinder if it is taken out of use for longer periods

Draining the WWK 300

- Turn off the WWK 300 as advised above.
- Close all hot water taps
- Operate the PTR valve release lever (do not let the lever snap back as you will damage the valve seat). This relieves the pressure in the WWK 300.
- Undo the union at the cold water inlet and attach a hose. The other end of the hose goes to a drain
- Operate the relief valve again. This will let air into the unit and allow the water to drain through the hose.

6. WARRANTY

Australia Only

Stiebel Eltron (Aust) Pty Ltd will;

- 1) Repair or if necessary replace the water heater, or
- 2) Replace any component which falls within the warranty period as specified below, subject to the warranty conditions and exclusions.

Notes:

Component	Period	Warranty
Cylinder	5 years	New water heater installed free of charge including labor*
Compressor #	2 Years	New components supplied and installed free of charge*
Electrical Components	1 Year	New components supplied and installed free of charge*

* If unit is located in a remote area an extra service charge may be applicable due to travel

Compressor warranty includes the sealed system components except for the condenser, e.g. Compressor, Expansion valve, Evaporator and associated pipe work. Condenser is included in cylinder warranty.

The warranty starts from the date of installation.

Stiebel Eltron does not accept liability for failure of any goods supplied which have not been installed and operated in accordance with the manufacturer ' s instructions.

For Service Telephone;

STIEBEL ELTRON (AUST) PTY LTD

1800 153 351



The installation, electrical connection and initial start-up of this appliance must only be carried out by a qualified contractor



Customer / Installer to fill out;

Customers name & Address	
Date of Install	/ /
Serial Number	
Installers name / Ph #	/
Invoice Number	

Please keep this in a safe place, as this will be required by the Stiebel Eltron technician if a Warranty call is required.

Address / Contacts**www.stiebel.com.au****VICTORIA****STIEBEL ELTRON VIC**

Unit 4, 8 Rocklea Drive

Phone: 03 9645 1833

Darren Fletcher: 0408 337 735

Port Melbourne VIC 3207

Fax: 03 9645 4366

Email: darren@stiebel.com.au

QUEENSLAND**STIEBEL ELTRON QLD**

Unit 4, 109 Riverside Place

Phone: 07 3399 3999

Glenn Day: 0419 718 822

Freecall: 1800 153 351

Morningside Qld 4170

Fax: 07 3399 3344

Email: glenn@stiebel.com.au

NEW SOUTH WALES / ACT**STIEBEL ELTRON NSW**

Unit 24, 110 Bourke Road

Ph: 02 8399 1088

Jason Kerr: 0419 778 354

Alexandria NSW 2015

Fax: 02 8399 1099

jason@stiebel.com.au

WESTERN AUSTRALIA**HIGGINS AGENCIES**

1/8 Juna Drive

Ph: 08 9248 7570

Malaga WA 6090

Fax: 08 9248 7590

TASMANIA**B & B AGENCIES**

2 Spinifex Road

Ph: 03 6243 9650

Risdonvale TAS 7016

Fax: 03 6243 9032

SOUTH AUSTRALIA**ENWARE**

11 Maria Street

Ph: 08 8352 3577

Thebarton SA 5031

Fax: 08 8352 4577

